

ELEVATION

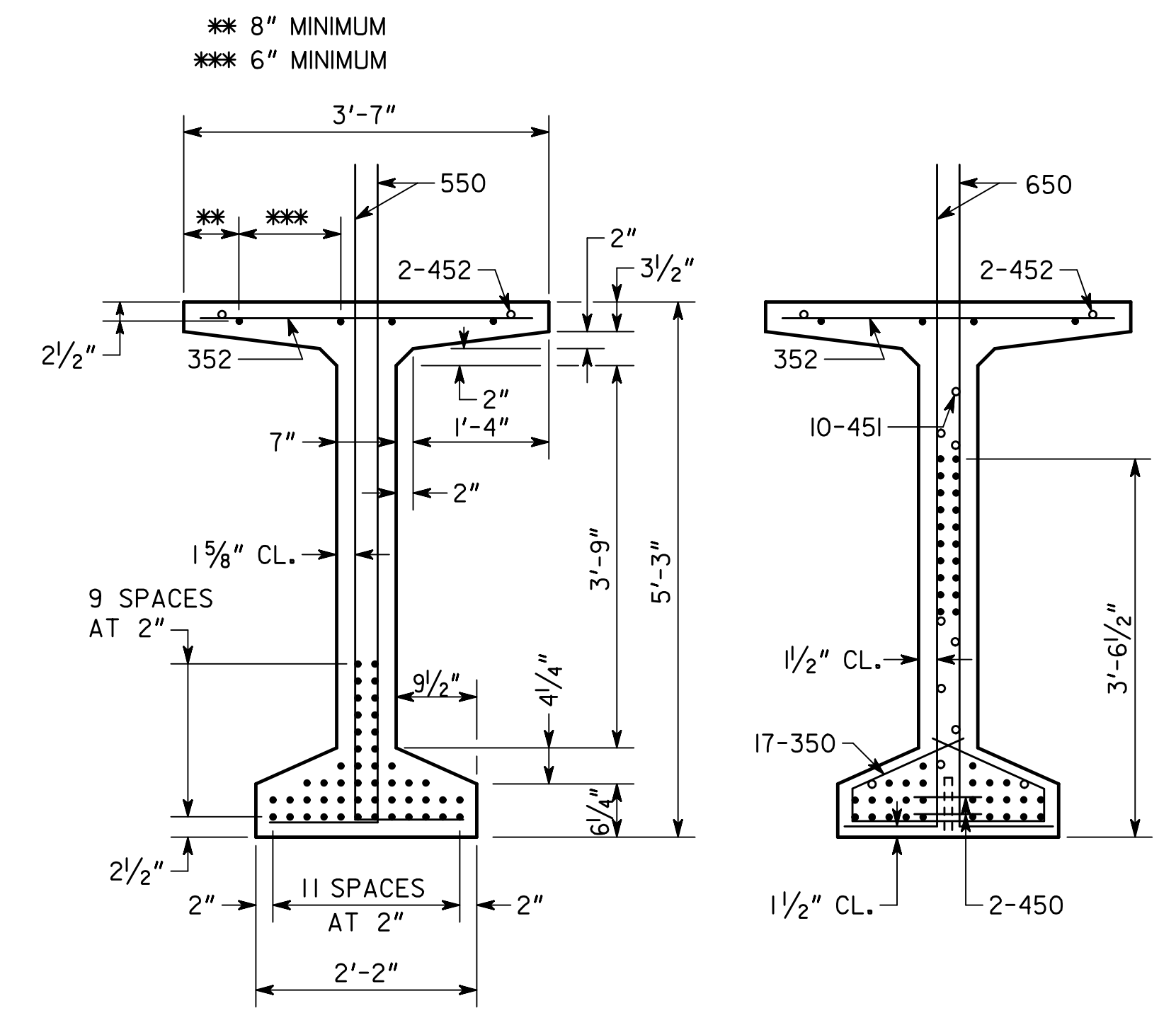

SECTION AT MIDPOINT SECTION AT END

NOTES

- BEAMS SHALL BE MAINTAINED IN AN UPRIGHT POSITION AT ALL TIMES AND SHALL BE PICKED UP WITHIN 7'-9" FROM THEIR ENDS. DISREGARDING THIS REQUIREMENT COULD LEAD TO COLLAPSE OF THE BEAM. PICK-UPS SHALL BE EMBEDDED TO WITHIN 4" OF THE BOTTOM OF THE BEAM. DETAILS OF PICK-UPS SHALL BE INCLUDED IN THE SHOP DRAWINGS.
- CHAMFER EDGES OF BEAMS 1/2", 3/4" OR 1".
- HORIZONTAL DIMENSIONS ARE IN PLACE DIMENSIONS. THE BEAM LENGTH INCLUDES THE 1/8" EPOXY MORTAR AT EACH END. SHOP DRAWINGS SHALL ADJUST HORIZONTAL DIMENSIONS FOR GRADE AND FABRICATION EFFECTS SUCH AS SHRINKAGE AND ELASTIC SHORTENING.
- AT ϕ BEARING, FORM A 1 3/4" DIAMETER X 7" DEEP HOLE AT THE FIXED ENDS AND A 6" X 1 3/4" X 7" DEEP SLOT AT THE EXPANSION ENDS FOR A 1 1/2" DIAMETER SMOOTH DOWEL. SEE PLAN AND ELEVATION SHEET FOR LOCATION OF FIXED AND EXPANSION ENDS.
- TOPS OF BEAMS SHALL BE ROUGH FLOATED AT APPROXIMATELY THE TIME OF INITIAL SET. ENTIRE TOP SHALL BE SCRUBBED TRANSVERSELY WITH A COARSE BRUSH TO REMOVE ALL LAITANCE AND TO PRODUCE A ROUGHENED SURFACE FOR BONDING TO THE SLAB. ROUGHENED SURFACE SHALL HAVE AN AMPLITUDE OF APPROXIMATELY 1/4". CONCRETE FINS OR PROJECTIONS SHALL BE REMOVED TO PRODUCE A VERTICAL FACE AT THE EDGE OF THE BEAM.
- NON-COMPOSITE DEAD LOAD DEFLECTION (Δ_{NC}) AT THE MIDPOINT IS DUE TO THE WEIGHT OF THE SLAB AND COPING.
- COMPOSITE DEAD LOAD DEFLECTION (Δ_C) AT THE MIDPOINT IS DUE TO THE WEIGHT OF BARRIER.
- STRANDS SHALL MEET ALL REQUIREMENTS OF ASTM A 416 GRADE 270.
- PRESTRESSING DATA IS AS FOLLOWS:
 - USE 52 - 0.6" DIAMETER LOW-RELAXATION ($A = 0.217$ SQ IN) STRANDS. PRETENSION TOP FOUR (4) STRANDS TO 10,000 LBS EACH. PRETENSION BOTTOM STRANDS TO 43,943 LBS EACH.
 - PRETENSIONED STRANDS SHALL BE RELEASED AFTER THE CONCRETE HAS REACHED A MINIMUM STRENGTH (f'_c) OF 8,000 PSI.
 - INCLUDING THE TOP STRANDS, THE TOTAL JACKING FORCE OF PRETENSIONING IS 2,149,264 LBS.
 - INCLUDING THE TOP STRANDS, THE NET PRESTRESSING FORCE OF THE STRANDS AFTER ALL LOSSES IS 1,628,102 LBS.
- CONCRETE STRENGTH (f'_c) = 8,500 PSI.
- ALLOWABLE PSC BEAM TENSION = 554 PSI.

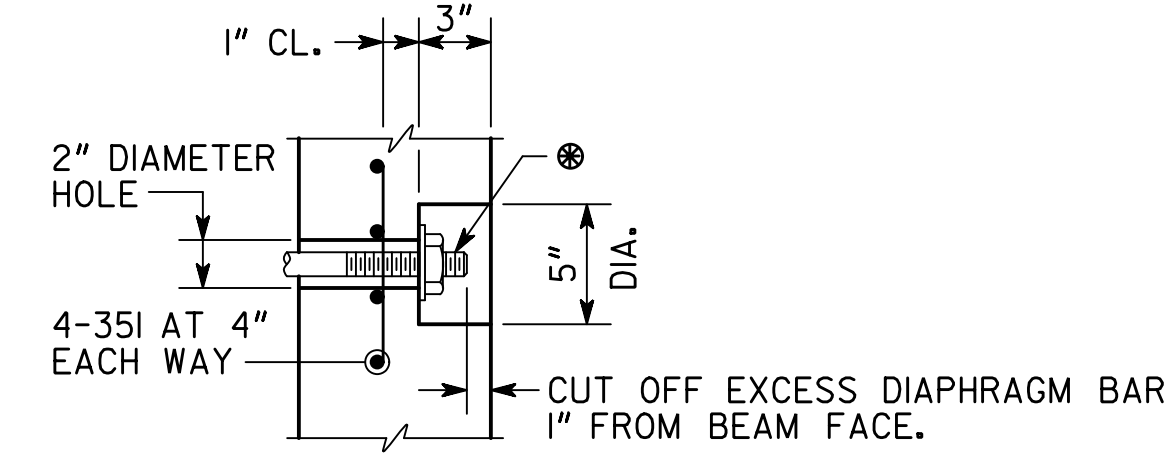

DIAPHRAGM BAR SHALL BE A 1" DIAMETER PLAIN BAR, THREADED 5" ON EACH END, WITH 1/4" X 3/2" DIAMETER WASHERS AND HEX NUTS (ASTM A 709 GRADE 36). TIGHTEN DIAPHRAGM BAR AS PER SUB-SECTION 507.3.05.C OF THE GEORGIA DOT SPECIFICATIONS. AFTER EXCESS DIAPHRAGM BAR HAS BEEN CUT OFF, PAINT DIAPHRAGM BAR, WASHER, AND NUT EXPOSED IN RECESS WITH SPECIAL PROTECTIVE COATING NO. 2 P AS PER SECTION 535 OF THE GEORGIA DOT SPECIFICATIONS. AFTER PAINTING, FILL THE RECESS WITH AN APPROVED EPOXY GROUT. GALVANIZING OF THE DIAPHRAGM BAR AS PER SUB-SECTION 865.2.01.B.12 OF THE GEORGIA DOT SPECIFICATIONS IS NOT REQUIRED.

RECESS DETAIL FOR DIAPHRAGM BAR ENDS

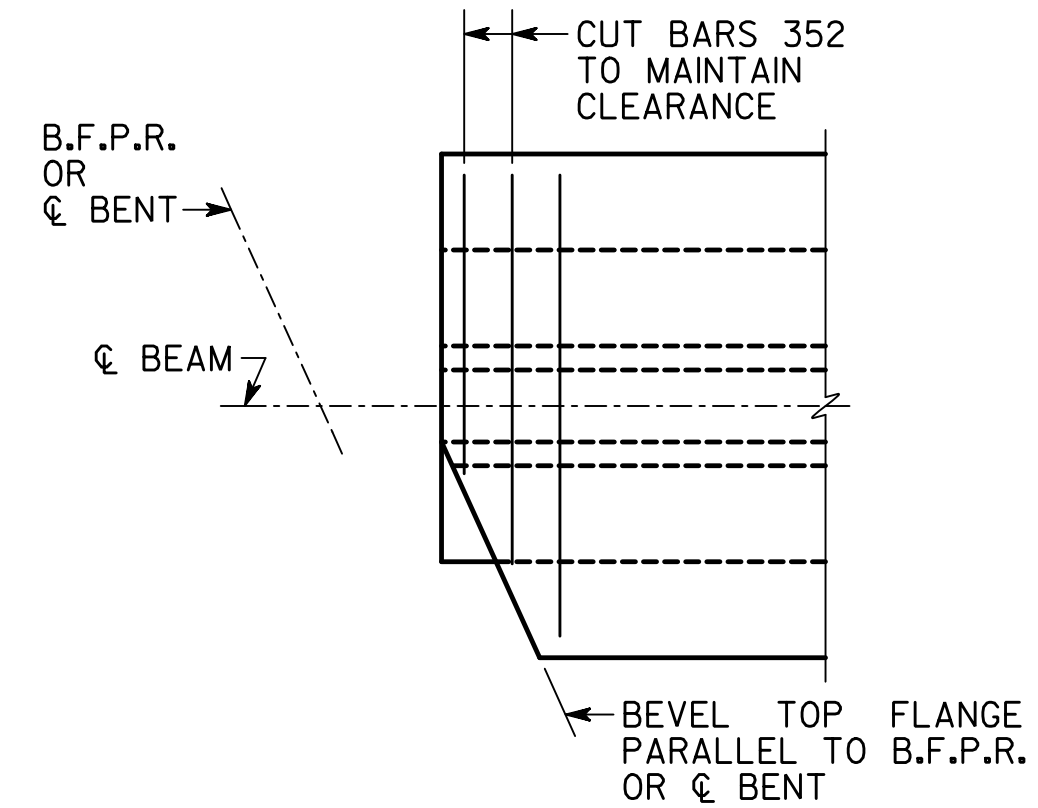

BEVEL DETAILS

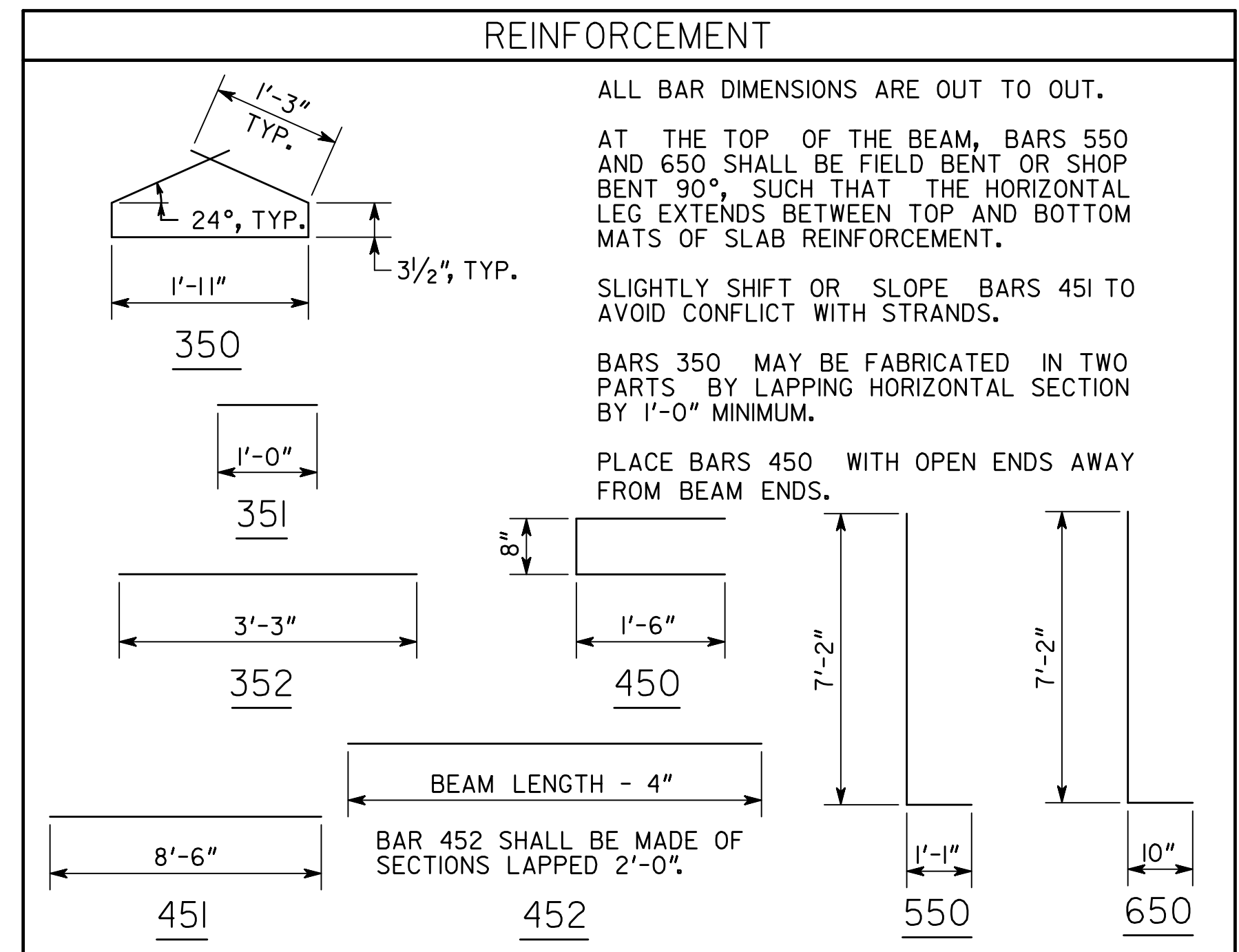

BRIDGE NO. 1

DATE		REVISIONS		BY	
GEORGIA DEPARTMENT OF TRANSPORTATION ENGINEERING DIVISION-OFFICE OF BRIDGES AND STRUCTURES MOD BULB TEE, 63 IN PSC BEAM - SPANS 2 AND 3 SR 83 OVER TOWALIGA RIVER MONROE COUNTY CSBRG-0007-00(046) NO SCALE MAY 2017					
DRAWING NO.	35-0008	DESIGNED	KNR	CHECKED	VMW
BRIDGE SHEET	8 OF 17	DRAWN	KNR	DESIGN GROUP	EJC
		REVIEWED	DLC/SKG	APPROVED	WMD

1 INCH WHEN PRINTED FULL SIZE

5/26/2017 5:56:28 PM 0007046_35-00_844