

**DEPARTMENT OF TRANSPORTATION
STATE OF GEORGIA**

SPECIAL PROVISION

SECTION 628—PERMANENT SOIL NAILED WALLS

628.1 General Description

This work includes furnishing materials, labor, tools, equipment, and other incidental items to design, detail, and construct a soil nailed wall. This Specification also applies to any Contractor-proposed alternate design of Department-furnished plans.

628.1.01 Definitions

Soil Nail - Synonymous with nail or soil reinforcing

The term Soil Nailed Wall includes the following items:

- Soil nails
- Nails
- Shotcrete (pneumatically applied concrete) – for temporary facing
- Cast-in-place reinforced concrete facing – for permanent facing
- Drainage

628.1.02 Related References

A. Standard Specifications

Section 500 - Concrete Structures

Section 511 - Reinforcement Steel

Section 853 - Reinforcement and Tensioning Steel

B. Referenced Documents

General Provisions 101 through 150.

628.1.03 Submittals

A. Proof of Ability

Submit the following proof of ability (or ability of the subcontractor) when requested by the Department to design or construct soil nailed walls:

- Evidence of successfully completing at least 5 projects similar in concept and scope to the proposed wall.
- Resumes of foremen, nail testing personnel, and drilling operators to be employed on this project. Show the type, length, and number of soil nails each has installed or tested within the past 5 years.
- Evidence of experience in nail testing. Persons performing nail testing shall prove experience by performing sample tests supervised by the Engineer.

The Department is the sole judge of the qualifications of the foreman, drilling operator, and testing personnel. Do not begin wall construction until the Engineer has approved proof of ability.

B. Design Criteria for Alternate Design

If the department receives more than 2 submittals of the Plans and calculations for review, the Contractor will be assessed \$60 per hour of engineering time for reviews in excess of the 2 submittals.

C. Construction Drawings and Design Notes

Submit construction drawings and design notes within 28 days of the award of the Contract. The Design Engineer shall prepare and stamp the submission. Include design notes and reproducible drawings in the submission concerning the following:

- Details, dimensions, and schedules of reinforcing steel including dowels and/or studs for attaching the facing to the soil nailed wall.
- Details of the shotcrete installation and nails, including the thickness of shotcrete and spacing and angle of installation of nails.
- Detailed plans for testing of nails showing loading and measuring devices to be used and procedures to be followed.

D. Final Wall Plans and Calculations

Submit final wall plans and calculations to the Department for review and approval before beginning construction on the wall. The time required for Plan and calculation review will be charged to the allowable Contract time. The Department has 30 days for Plan and calculation review per item after receiving the structure calculations and drawings.

New submittals from the Contractor showing corrections from the Department's review or changes to ease construction or to correct field errors have a 30-day review. The Department is the sole judge of information adequacy.

The Department's review and acceptance of the final Plans and construction methods do not relieve the Contractor from successfully completing the work. Time extensions are not granted for Contractor delays from untimely submissions or insufficient information.

E. Admixture Literature

Before using an admixture, submit the manufacturer's literature to the Engineer. Indicate the admixture type and the manufacturer's recommendations for mixing the admixtures with grout.

628.2 Materials

A. Concrete

Use concrete conforming to Section 500.

B. Reinforcing Steel

Use reinforcing steel conforming to Section 511. Reinforcing steel used as soil nails shall be full length. Couplers will not be allowed.

C. Structural Steel

Use structural steel shapes or plates conforming to Section 501. Use ASTM A 709 Grade 36 (Grade 250) structural steel unless otherwise specified on the plans.

D. Cement Grout

Produce cement grout using Portland cement conforming to AASHTO M-85, Type I, II, or III, and potable water. Use cement that is fresh and free of lumps and hydration.

Follow these restrictions if using admixtures:

1. Do not use admixtures with chemicals that may harm the soil nail, reinforcing steel, or cement.
2. Do not use admixtures that cause air bubbles in the grout.
3. If approved by the Engineer, use admixtures imparting low water content, flowability, and minimum bleeding in the cement grout.

E. Plastic

Use Polyethylene conforming to AASHTO M-252 with a minimum wall thickness of 30 mils (0.76 mm) for corrosion protection.

F. Shotcrete

Use shotcrete conforming to the following:

1. Cement – Section 830.2.01 Type I, II or III.
2. Fine Aggregate – Section 801.2.02.

3. Coarse Aggregate – Section 800.2.01.
4. Fly Ash – Section 831.2.03
5. Silica Fume – AASHTO M-307.
6. Air Entraining Admixtures for wet mix – Section 831.2.01.
7. Plasticizers – AASHTO M-194, Type A, D, F, G.
8. Use accelerating admixtures that are compatible with the cement, are non-corrosive to steel and do not promote other detrimental effects such as cracking and excessive shrinkage and do not contain calcium chloride. Use admixtures in accordance with the manufacturer's recommendations. Silica fume, if used, shall not exceed 10 percent of the cement weight and shall be an admixture with a minimum of 90 percent SiO₂ with a proven record of performance in shotcrete.
9. Use water in shotcrete that is potable, clean, free from substances which may be injurious to concrete and steel, and is free of elements which would cause staining.
10. Provide premixed and prepackaged concrete products specifically manufactured as a shotcrete product for on-site mixed shotcrete, if approved by the engineer. The packages shall contain cement and aggregates conforming to Section 500.

G. Corrosion Inhibitor

Use corrosion inhibitor (grease) conforming to the following:

1. Drop point 300 degrees F (149 degrees C) minimum by ASTM D-566.
2. Flash point 300 degrees F (149 degrees C) minimum by ASTM D-92.
3. Water content 0.1% maximum by ASTM D-95.
4. Rust test – Rust Grade 7 or better after 720 hours, aggressive conditions: Rust Grade 7 or better after 1000 hours by ASTM B-117 and ASTM D-610.
5. Water soluble ions.

Chlorides	10 ppm maximum	by ASTM D-512
Nitrates	10 ppm maximum	by ASTM D-3867
Sulfates	10 ppm maximum	by APHA 427D (15 th ED)
6. Oil separation – 0.5% by weight maximum at 160 degrees F (71 degrees C) by FIMS 719B, Method 321.2.
7. Soak test – 5% Salt Fog at 100 degrees F (38 degrees C), 5 mils (0.13 mm) (Q Panel Type S), immerse panels in 50% salt solution and expose to 5% Salt Fog – no emulsification after 720 hours by ASTM B117 Modified.

628.2.01 Delivery, Storage, and Handling

A. Protection Systems

Protect soil nails against corrosion by properly storing, fabricating, and handling the nail components before inserting them into the borehole. Avoid prolonged exposure of the nail components to the elements, and avoid mechanical or physical damage that reduces or impairs the component's ability to resist adverse conditions during service. Nail components will be rejected for heavy corrosion or pitting, but not for a light coating of rust.

Use the protection systems as follows:

1. Soil Nail

Protect the entire length of the soil nail from the anchor plate to the end of the nail from corrosion.

 - a. Encase the nail in a corrugated plastic tube.
 - b. Use cement grout to fill the voids between the tube and the nail and the tube and the soil. Place cement grout between the soil and the tube to at least ¾ in (20 mm) thick and extend the entire length of the nail. Cement grout between the tube and the nail shall be a minimum of ½ in (12 mm) thick
 - c. Provide centralizers spaced at a maximum of 5 feet (1.5 m) center-to-center throughout the nail length. Do not use wood or material harmful to the soil nail or the corrugated plastic tubing as centralizers.
 - d. Provide a smooth piece of plastic sheath to encapsulate the entire free length. Do not splice the sheath. Ensure that the sheath is at least 0.05 in (1.27 mm) thick. Provide a void space between the sheath and the steel as shown on the plans and maintain that space with centralizers. Fill visible void space with grease and seal the bottom to prevent grout intrusion.

2. Area Underneath Anchorage

Protect the area immediately behind the stressing anchorage.

- a. Weld a pipe sleeve to the bearing plate and seal the pipe sleeve to the anchor sheath at the other end of the sleeve.
 - b. Clean the pipe sleeve to remove dirt, rust, or other harmful material before inserting the soil nail into the pipe sleeve.
 - c. If a seal is not provided at the lower end of the pipe sleeve, during installation and grouting, fill the lower end of the pipe sleeve with grout. Keep the pipe sleeve free of harmful material until the upper portion of the pipe sleeve and anchor head are filled with grout.
 - d. Fill the void inside the sleeve and anchor head with anti-bleed expansion grout after the nails have been stressed.
3. Anchorage
Encase the anchorage system head into a corrosion protective system before proceeding to the next lift. Install the protective system for each lift within 30 days after installing the nails for that lift. Ensure that the anchorage system has a cover of at least 3 in (75 mm) once the wall face is placed.

628.3 Construction Requirements

628.3.01 Personnel

A. Contractor Qualifications

The Contractor and Subcontractor shall be experienced in constructing permanent soil nailed walls. Provide at least one Registered Professional Engineer licensed to perform work in the State of Georgia and a supervising Engineer for the Project with at least 5 years of experience in constructing permanent soil nailed walls.

Furnish verification of these qualifications to the Engineer before beginning operations.

B. Design Engineer

The Design Engineer shall:

- Be registered as a Professional Engineer in the State of Georgia
- Have considerable knowledge and experience designing and constructing soil nailed walls
- Be available at any time during the Contract to discuss the design of the walls with the Department.

C. Registered Professional Engineer

Retain the services of a second Professional Engineer licensed to perform work in the State of Georgia and prequalified by the Department. The Engineer shall operate independently from the Professional Engineer of Subsection 628.3.01.B, "Design Engineer."

This Engineer will independently check the design calculations and Plan details for the permanent soil nailed wall before submitting them to the Department.

628.3.02 Equipment

Use anchorage and hardware suitable for the type of soil nails used. Ensure that the anchorage and hardware are capable of the following:

- Developing 75 percent of the yield capacity of the nails when tested in the unbonded state and without failure of the nail
- Holding the soil nail at a load producing a stress of not less than 75 percent of the yield capacity of the nail without exceeding the anticipated set and without causing anchorage or soil nail failure
- Test nails shall be capable of lifting-off, detensioning, or retensioning a nail before secondary grouting to fill voids at the top of the pipe sleeve.

628.3.03 Preparation

Before beginning the work, survey the condition of the adjoining properties. Keep records and photograph settlement or cracking of adjacent structures that may become the subject of possible damage claims. Deliver the report to the Department before beginning work at the site.

Obtain a Foundation Investigation Report from the Geotechnical/Environmental Bureau of the Department to assist in evaluating existing conditions for design and construction.

628.3.04 Fabrication

A. Soil Nails

Fabricate the soil nails according to the approved details.

1. Keep the nails free of dirt, rust, and other harmful substances.
2. Use a plastic sheath that is a single piece without splices.
3. Before installation, handle and store the nails so as to avoid corrosion and physical damage. Nails will be rejected for damage such as abrasions, cuts, nicks, welds, weld splatters, or heavy corrosion and pitting. Replace the nails at the Contractor’s expense for material replacements or time delays.

628.3.05 Construction

A. Design Criteria

The design criteria for a proposed design or design include:

1. Design soil nails according to this Specification.
2. Use reinforced concrete facing according to the latest AASHTO Standard Specifications for Highway Bridges, including interims. Ensure that the structural thickness is at least 12 in (300 mm). Provide architectural facing treatment as shown on the Department drawings.
3. Ensure that the concrete strength is at least 3000 psi (20 MPa) 28-day strength. Extend the facing 2 ft (600 mm) below the gutterline or, if applicable, the ground line adjacent to the wall unless otherwise indicated on the Department Plans.
4. Design and install permanent drainage systems behind the wall. Connect the drainage systems to the nearest drop inlet using pipe or free drainage through traffic barriers or other obstructions. Ensure that holes through traffic barriers and/or facing are no higher than 3 in (75 mm) above the gutterline or ground line.
5. Ensure that the wall is compatible with the horizontal and vertical criteria indicated in the Department Plans.
6. Provide a wall design that is adequate to resist sliding, overturning and bearing forces. Safety factors shall be as follows:

Sliding	1.50
Overturning	2.00
Bearing	1.00

Design the wall for the design condition shown in Figure 1.

7. See Figure 3 for typical section of permanent soil nail wall.

B. Ground Movements and Load Transfer Instruments

During construction of the wall, the Department may install devices to monitor ground movements and load transfers during or after construction. The Department will schedule installation to minimize interference with the Contractor’s operations. Cooperate with the instrumentation installers. Anticipate delays of two to four hours per instrumented nail.

Although the Instrumentation Specialist maintains the instruments, assume responsibility for damage to the instruments, connections or readouts from operations. Replace and install damaged equipment at the Department’s approval and at the Contractor’s expense.

C. Soil Nail Installation

Install the soil nails as follows:

1. Before installation, visit the site to observe existing conditions that may affect the work or design, if applicable, and to review the geotechnical data available for the Project.
2. Drive or drill the holes for the soil nails by core drilling, rotary drilling, auger drilling, or percussion drilling. If using water in the drilling operation, dispose of the water to minimize wall erosion. Repair water erosion damage to the site at no cost to the Department.
3. If the hole will not stand open, install casing to maintain a clean and open hole. Ensure that the hole diameter is at least 3 in (75 mm) if no pressure grouting is used. Pressure grouting is grouting with a pressure greater than 60 psi (415 kPa).
4. Ensure that the drill bit diameter is not more than 1/8 in (3 mm) smaller than the specified hole diameter.
5. Start soil nail holes within an angle tolerance of 3 degrees from the inclination specified on the approved design Plans. Do not allow the holes to deviate from a straight line by more than 2 in (50 mm) in 10 ft. (3 m). Do not allow the holes to extend outside the Right-of-Way limits. Thoroughly clean the holes of all dust, grease, or other deleterious material before inserting the nail.
6. Install the nail in the casing or the hole drilled for the nail. Ensure that the nail’s corrosion protection is not damaged during handling or installation.
7. Install the nail in the bond length to achieve at least 1½ in (38 mm) of grout cover.
8. Do not use nails to ground electric equipment and do not subject the nails to sharp bends.

9. Provide centralizers spaced a maximum of 5 ft (1.5 m) center to center throughout the nail length. Do not use spacers of wood or other material harmful to the nail or corrosion protection.
10. Inject grout at the lowest point of the nail and place over the entire length of the nail.
 - a. Ensure that the grouting equipment can continuously mix and produce lump-free grout. Equip the grout pump nozzle with a grout pressure gauge capable of measuring pressure of at least 150 psi (1 MPa) or twice the actual pressure used.
 - b. Base the material proportions used in the grout on grout tests made before beginning grouting; or select the proportions based on prior documented experience with similar materials and equipment under comparable field conditions.
 - c. Use the minimum water content necessary for proper placement and do not exceed a water-cement ratio of 0.45. Do not leave the grout in the mixer longer than 45 minutes.
11. After grouting, do not disturb the nail until the grout has reached a cube strength of 3500 psi (25 MPa). Keep the mouth of the hole clean after grouting. Record the following data in a Project field book during the grouting operation:
 - Type of mixer
 - Water-cement ratio
 - Type of additives
 - Grout pressure
 - Type of cement
 - Test sample strengths (before stressing)
 - Volume placed in bond and free lengths
12. If using pressure grouting, choose whether to perform a water-tightness test. However, if injecting grout with a pressure of 60 psi (415 kPa) or less, always perform a water-tightness test. Perform the test as follows:
 - a. Fill the entire hole in the rock with water and subject it to a pressure of 5 psi (35 kPa) in excess of the hydrostatic head as measured at the top of the hole.
 - b. If after 10 minutes the leakage rate from the hole exceeds 0.001 gal per inch diameter per foot of depth per minute (0.5 ml per mm diameter per meter of depth per minute), consolidate grout, redrill, and retest the hole. If the second water-tightness test fails, repeat the entire process.
 - c. During the tests, observe holes adjacent to the hole being tested for water-tightness to detect and seal inter-hole connections.
 - d. If artesian or flowing water is encountered in the drilled hole, maintain the pressure on the consolidation grout until the grout has initially set.

D. Temporary Shotcrete Facing

Provide temporary shotcrete facing.

1. Shotcrete Quality - Produce the shotcrete by the wet mix process and achieve a minimum compressive strength of 3000 psi (20 MPa) in seven (7) days and 4600 psi (32 MPa) in 28 days.
2. Mixture Proportions - Submit for acceptance the recommended mixture proportions, strength results, water cement ratio, and source of materials. Select the mixture proportions based on compressive strength tests of specimens continuously moist cured until tested at 28 days in accordance with AASHTO T-22. Use a maximum water cement ratio of 0.40, air content of $6.5\% \pm 1.5\%$, slump of 1.5 to 3 inches (38 to 50 mm). The mixture is acceptable if the average core compressive strength is at least 1.2 times the required compressive strength in 628.4.07.A above.
3. Batching and Mixing - Batch aggregate and cement by weight or by volume. Provide mixing equipment capable of thoroughly mixing the materials in sufficient quantity to maintain placing continuity. Provide ready-mix shotcrete complying with AASHTO M-157.
4. Delivery Equipment - Provide equipment capable of delivering the premixed materials accurately, uniformly and continuously through the delivery hose. Follow the recommendations of the equipment manufacturer on the type and size of nozzle to be used, and on cleaning, inspecting and maintaining the equipment. Deliver ready-mix shotcrete in transit mixers that comply with AASHTO M-157. Provide a supply of clean, dry air adequate for maintaining sufficient nozzle velocity for all parts of the work and, if required, for simultaneous operation of a suitable blow pipe for clearing away rebound. Provide a compressor capable of providing a minimum of 315 cfm (8.9 m³/min) per operating nozzle.
5. Curing:
 - a. Keep shotcrete continuously moist for 24 hours after completion by one of the following methods or materials:
 - Continuous sprinkling

- Absorptive mat or fabric, or other covering kept continuously moist
 - Curing compounds in accordance with Section 500.3.05.Z. On natural gun or flash finishes, apply one gallon per 100 square feet (0.4 l per square meter). Do not use curing compounds on any surfaces against which additional shotcrete or other cementitious finishing materials are to be bonded unless positive measures, such as sandblasting, are taken to completely remove curing compounds prior to application of such additional materials.
- b. Provide final curing immediately following the initial curing and before the shotcrete has dried by one of the following materials or methods:
 - Continuation of the method used in the initial curing
 - Application of impervious sheet material conforming to AASHTO M-171.
 - c. Continue curing for the first seven days after shotcreting or until the required seven-day strength is obtained. During the curing period, maintain the shotcrete above 38 degrees F (3.3 degrees C) and in a moist condition as specified.
6. Construction Testing - Cut cores from the structure and test in accordance with AASHTO T-24. Take a minimum of three cores from each 1000 square feet (93 square meters) of completed facing. Alternatively, construct a test panel with minimum dimensions of 18 X 18 X 4 in (450 X 450 X 100 mm) gunned in the same position as the work represented for each 1000 square feet (93 square meters) of completed facing. The Contractor's regular nozzle men shall gun the panels during the course of the work. Field cure the panels in the same manner as the work, except that the test panels shall be soaked for a minimum of 40 hours prior to testing. Cut a minimum of three cores from each panel for testing in accordance with AASHTO T-24. The average compressive strength of each core of a set of three cores must equal or exceed 85 percent of the compressive strength specified in 628.3.05.A.

E. Permanent Cast-In-Place Facing

Provide permanent cast-in-place reinforced concrete facing in accordance with the requirements of this specification, as shown in the plans and the following:

1. Provide vertical expansion joints at a maximum spacing of 90'-0"
2. Provide vertical contraction or construction joints at a maximum spacing of 30'-0"
3. Form vertical rustication grooves at a maximum spacing of 10'-0". Rustication grooves are to be equally spaced between expansion joints and coincide with construction joints.
4. Provide studs in the construction of the soil nail system for anchoring the cast-in-place facing.

628.3.06 Quality Acceptance

A. Nail Testing and Acceptance

Perform testing according to this subsection.

Perform load tests on at least 5% of the nails in each row to verify the soil-to-grout bond stress used in the design.

Provide separate nails specifically for the purpose of testing. Test nail locations shall be approved by the Engineer. Test nails will not be considered part of the permanent support system. Install the test nails in accordance with Figure 2.

Grout only the bonded length of the nail prior to testing. Provide and use the following testing equipment:

- A dial gauge that can measure elongation to the nearest 0.001 in (0.025 mm)
- A hydraulic jack and pump with a pressure gauge graduated in increments of 100 psi (690 kPa) or less.

Test by incrementally loading the nail according to the following schedule:

- AL
- 0.25P
- 0.50P
- 0.75P
- 1.00P
- 1.25P
- 1.50P

where:

AL = minimum load required to support the jacking system tightly against the bearing surface = 2 kips (8.9 kN).

P = design load

Measure the nail movement with the dial gauge fixed to an independent reference point. Apply the load with a hydraulic jack and measure it with a hydraulic pressure gauge. Increase the load from one increment to the next immediately after the nail movement is recorded.

Hold the maximum test load for ten (10) minutes. Start the load hold period as soon as the maximum test load is applied, and measure the nail movements at one (1), two (2), three (3), four (4), five (5), six (6), and ten (10) minutes. The nail

test is acceptable if the nail carries the maximum test load with less than 0.08 in (2 mm) of movement between one (1) and ten (10) minutes.

If the nail fails the test, determine the cause. If the failure indicates that the nails will not achieve the design soil-to-grout bond stress, then modify the design and/or construction procedures. These modifications may include, but are not limited to, installing replacement nails, reducing the design bond stress by increasing the number of soil nails or by lengthening the nails, or modifying the installation methods. After modifications, test the nails for acceptance of the new design. Make the modifications of the design and/or construction procedures at no cost to the Department unless the modifications are due to changed conditions.

After completion of testing and determination of acceptance, detension all test nails and all nails shall be tensioned to 200 ft-lb (270 N-m) of torque.

628.4 Measurement

Permanent Soil Nailed Walls are not measured separately for payment.

628.5 Payment

Payment for this work is made per Lump Sum. Payment includes costs for concrete, reinforcing steel, excavation, backfill, shotcrete, soil nails, anchorages, labor, design, and all other materials and equipment. Payment also includes grouting, drilling holes, performing and evaluating all tests, submitting records of tests, all tools and all other items to complete the work.

Payment will be made under:

Item 628	Permanent Soil Nailed Wall, wall no. ____	Per lump sum
----------	---	--------------

628.5.01 Adjustments

Additional wall area required because of unforeseen foundation conditions or other reasons that are approved by the Engineer will be paid for by adjusting the Lump Sum Price Bid. If the wall area is increased or decreased, the Lump Sum Price Bid will be adjusted proportionally based on the change in wall area as determined from the stations, elevations and dimensions on the Plans.

No additional compensation will be made for additional material, equipment, design, or other items to comply with the Project specifications as a result of the Department's review of the contractor's design.

OFFICE OF BRIDGE DESIGN

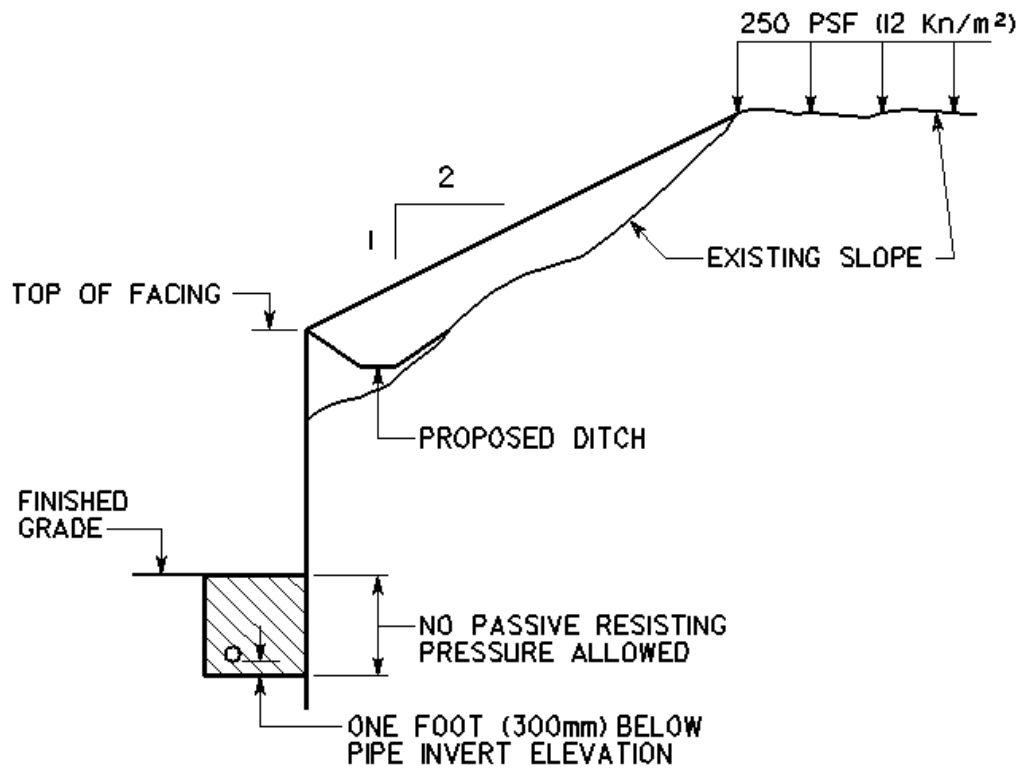

DESIGN CONDITION

FIGURE 1

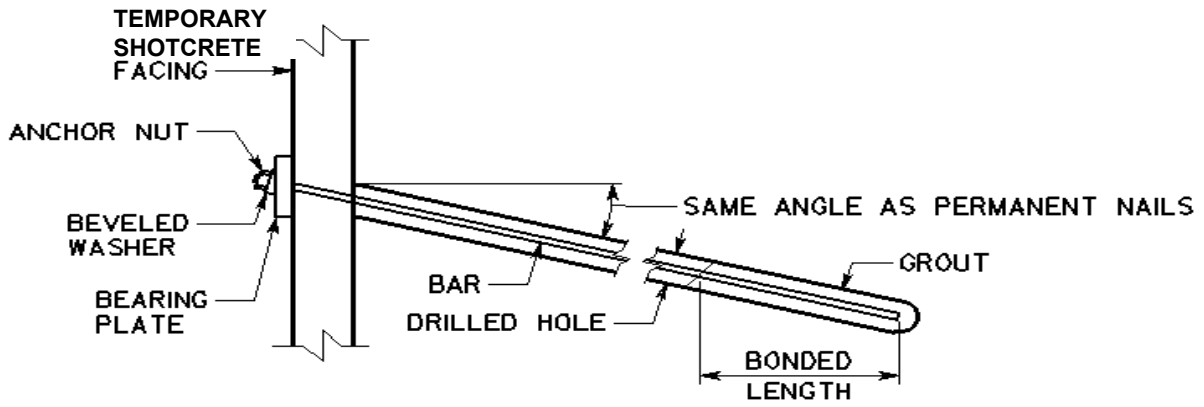

TEST NAIL DETAIL
NO SCALE

FIGURE 2

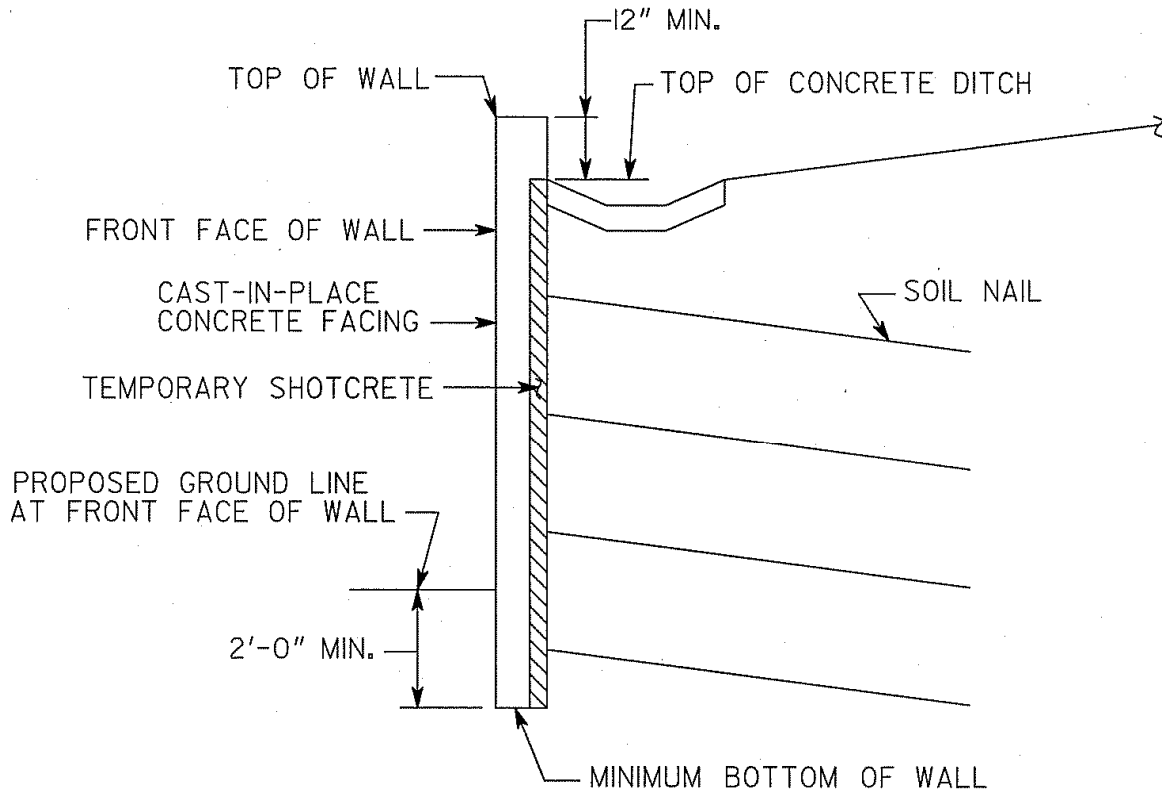

FIGURE NO. 3