

MAX. HEIGHT	WALL DIMENSIONS					REINFORCEMENT				Δ (INCHES)	MAX. FACTORED BEARING PRESSURE	TYPE
	D	E	F	H	T	S	X	Y	Z			
6'	1'-0"	2'-4"	6'-10"	4'-9"	1'-0"	#5 AT 8"	#5 AT 8"	#4 AT 8"	#4 AT 12"	0"	2.3 KSF	P1
8'	1'-0"	2'-4"	7'-3"	5'-2"	1'-0"	#5 AT 8"	#5 AT 8"	#5 AT 8"	#4 AT 12"	1/8"	2.6 KSF	P2
10'	1'-3"	2'-4"	8'-6"	6'-5"	1'-0"	#5 AT 7"	#5 AT 7"	#5 AT 7"	#4 AT 12"	1/4"	2.9 KSF	P3
12'	1'-3"	2'-9"	10'-0"	7'-8"	1'-3"	#6 AT 7"	#6 AT 7"	#6 AT 7"	#4 AT 12"	7/16"	3.2 KSF	
14'	1'-3"	3'-2"	11'-7"	8'-6"	2'-0"	#7 AT 6"	#7 AT 6"	#7 AT 6"	#4 AT 12"	1/2"	3.3 KSF	

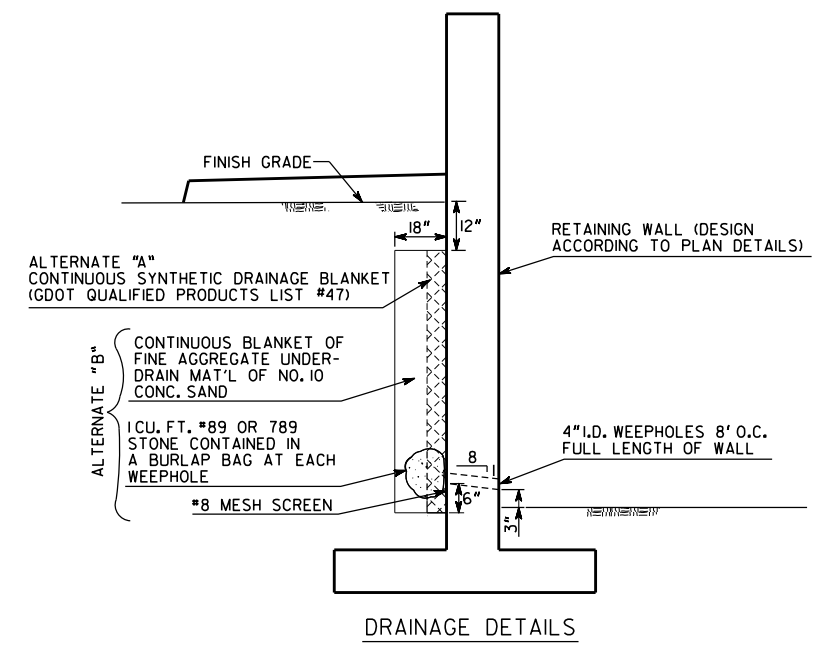
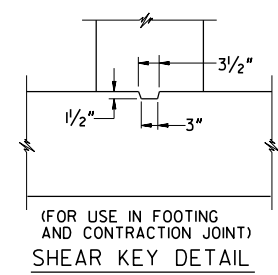
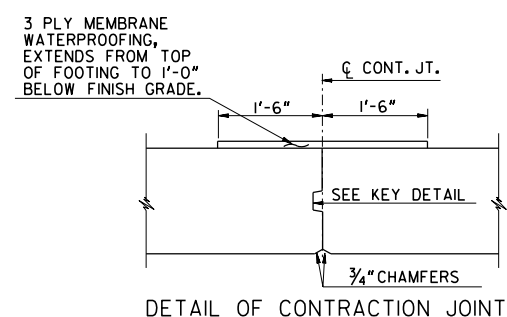
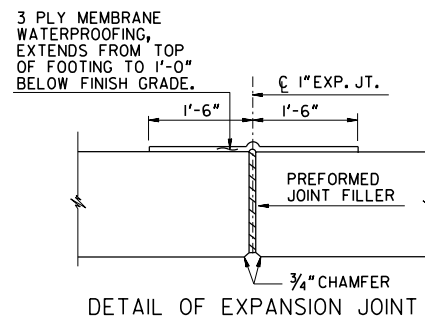
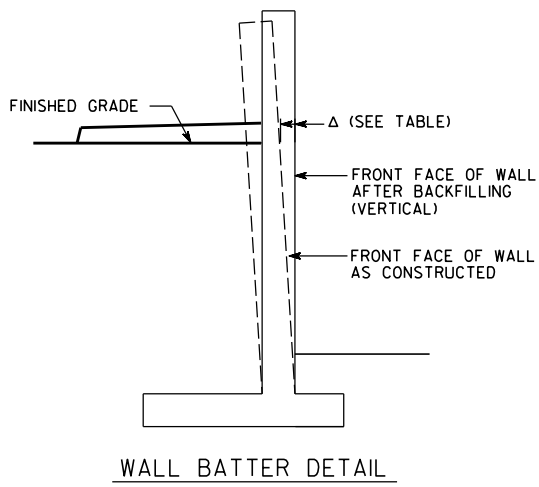
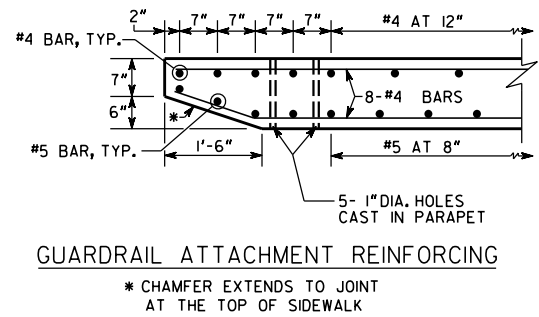
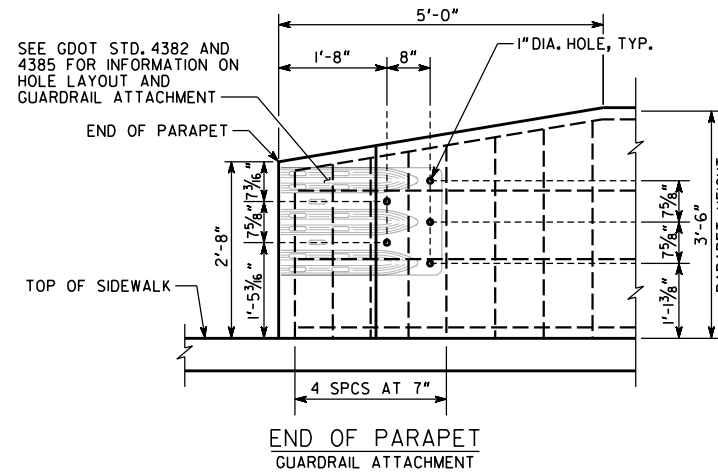

- GENERAL NOTES:
- SPECIFICATIONS: GEORGIA STANDARD, CURRENT EDITION, AND SUPPLEMENTS THERETO.
 - CONCRETE SHALL BE CLASS "A". REINFORCING STEEL SHALL BE GRADE 60.
 - DRAINAGE DETAIL ALTERNATES A OR B, PER THE DETAIL ON THIS SHEET, ARE REQUIRED FOR TYPE P1, P2, AND P3 RETAINING WALLS. INCLUDE COSTS OF MATERIALS AND WORK IN PRICE BID FOR CLASS A CONCRETE, (TYPE) RETAINING WALL.
 - MAINTAIN 2" COVER ON ALL REINFORCING IN STEM AND PARAPET AND 3" COVER IN FOOTING. USE OF FORMLINERS PER THE CONTRACT WILL REQUIRE OVERALL STEM AND PARAPET WIDTHS TO BE INCREASED TO MAINTAIN COVER.
 - EXPOSED CONCRETE SURFACES SHALL RECEIVE A TYPE III FINISH UNLESS A FORMLINER IS REQUIRED PER THE CONTRACT.
 - APPLY A GRAFFITI PROOF COATING AS PER SECTION 838 TO ALL EXPOSED CONCRETE SURFACES.
 - PARAPET WALLS OVER 20'-0" IN LENGTH SHALL HAVE CONTRACTION JOINTS SPACED AT A MAXIMUM OF 20'-0". CONTRACTION JOINTS SHALL EXTEND THROUGH THE PARAPET, AND STEM. PARAPET WALLS OVER 80'-0" IN LENGTH SHALL HAVE EXPANSION JOINTS SPACED UNIFORMLY AT A MAXIMUM SPACING OF 80'-0" WITH 1" PREFORMED JOINT FILLER EXTENDING THROUGH PARAPET, STEM, AND FOOTING AT EACH EXPANSION JOINT. GALVANIZED 10# NAILS SHALL BE USED TO INSTALL EXPANSION MATERIAL.
 - PLACE AND TIE ALL REINFORCING STEEL IN ACCORDANCE WITH THE GEORGIA DOT SPECIFICATIONS. DO NOT WELD REINFORCING STEEL. LONGITUDINAL REINFORCING SHALL NOT EXTEND THROUGH EXPANSION JOINTS. STEM LONGITUDINAL REINFORCING SHALL NOT EXTEND THROUGH CONTRACTION JOINTS. LONGITUDINAL REINFORCING SHALL BE LAP SPliced 2'-5". LONGITUDINAL FOOTING REINFORCING SHALL BE CONTINUOUS BETWEEN EXPANSION JOINTS. WHEN FOOTING SIZE CHANGES, LONGITUDINAL REINFORCING FOR SMALLER FOOTING SHALL EXTEND 1'-10" MINIMUM INTO LARGER FOOTING.
 - EXPANSION AND CONTRACTION JOINTS IN TYPE P1, P2, AND P3, RETAINING WALLS SHALL BE WATERPROOFED ON THE BACK SIDE. WATERPROOFING SHALL BE 3-PLY AND EXTEND FROM 1'-0" BELOW FINISH GRADE TO TOP OF FOOTING FOR 1'-6" MIN. EACH SIDE OF JOINT.
 - TYPE P1, P2, AND P3 RETAINING WALLS SHALL BE PAID FOR PER LINEAR FOOT AS CLASS A CONCRETE, (TYPE) RETAINING WALL. INCLUDE COSTS FOR WATERPROOFING, EXCAVATION, BACKFILLING, CONCRETE, REINFORCING STEEL AND ALL INCIDENTALS IN THE PRICE BID.
 - TYPE P1, P2, AND P3 RETAINING WALLS HAVE BEEN DESIGNED IN ACCORDANCE WITH THE AASHTO LRFD BRIDGE DESIGN SPECIFICATIONS, 8TH EDITION, 2017. THE PARAPETS INCLUDED IN THE DESIGN HAVE BEEN CERTIFIED BY THE DEPARTMENT TO SATISFY MASH TL-4 REQUIREMENTS FOR PROJECTS IN GEORGIA.
 - RETAINING WALLS DESIGNED FOR THE FOLLOWING SOIL PROPERTIES:

	FOUNDATION	BACKFILL
COHESION =	0 KSF	0 KSF
φ =	28°	28°
UNIT WT. =	0.120 KCF	0.120 KCF
 - WIRE FABRIC REINFORCING OR ALTERNATE REBAR SIZE/SPACING MAY BE USED IF DETAILS ARE SUBMITTED TO AND APPROVED BY THE ENGINEER PRIOR TO USE.
 - WHERE GUARDRAIL ATTACHMENT IS REQUIRED, PAYMENT FOR THE FIVE 1" DIAM. HOLES, PROPERLY LOCATED FOR CONNECTING THE SPECIAL END SHOE SHALL BE INCLUDED IN THE PRICE BID FOR CLASS A CONCRETE, (TYPE), RETAINING WALL BASED ON STEM HEIGHT REQUIRED. SHIFT PARAPET REINFORCING TO MISS BOLT HOLES AS REQUIRED.

DATE		DEPARTMENT OF TRANSPORTATION	
		STATE OF GEORGIA	
REVISION		STANDARD	
		PARAPET RETAINING WALL	
		TYPES P1, P2, AND P3	
NO SCALE		MAY 2020	
BY	DES. DDF (SUBMITTED)	NUMBER	
	DRW. DDF	4949D	
	CHK. CEW (APPROVED)		
	REV. WMD/BAS		
	STATE DESIGN POLICY ENGINEER <i>Christopher Rudd</i>		
	CHIEF ENGINEER <i>Margaret B. Pirelo</i>		