

Typical Section at Willis Still Road

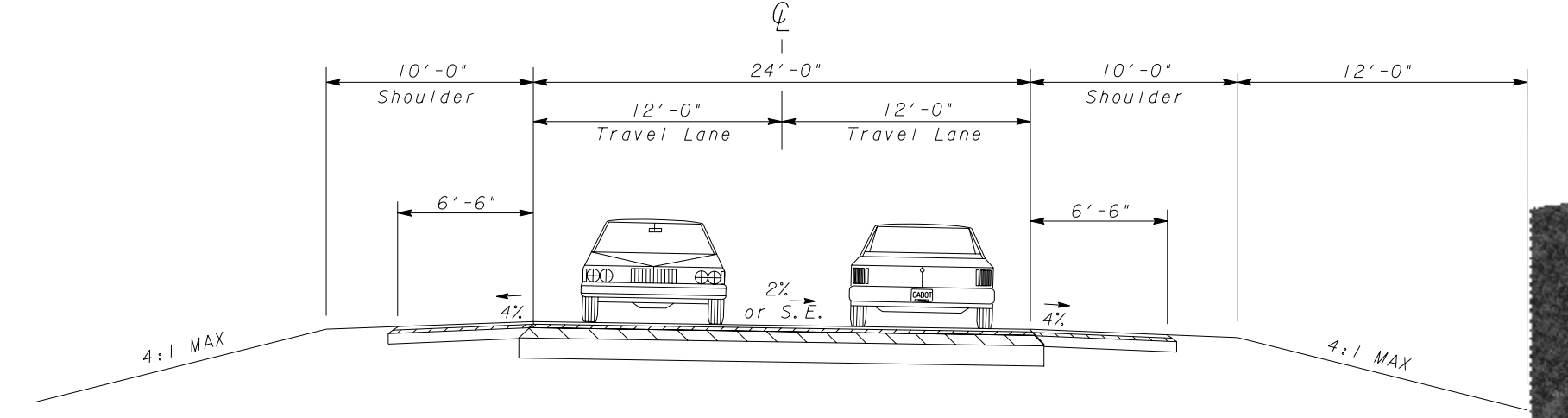

Typical Section at Frontage Roads

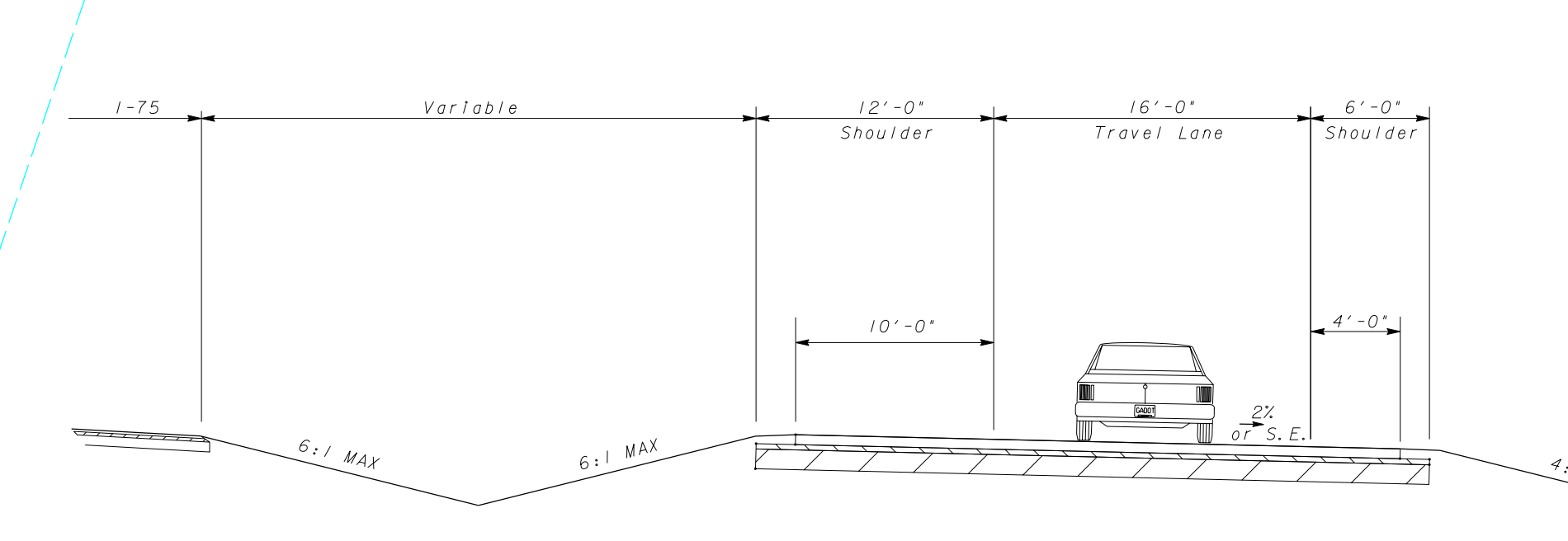

Ramp Typical Section

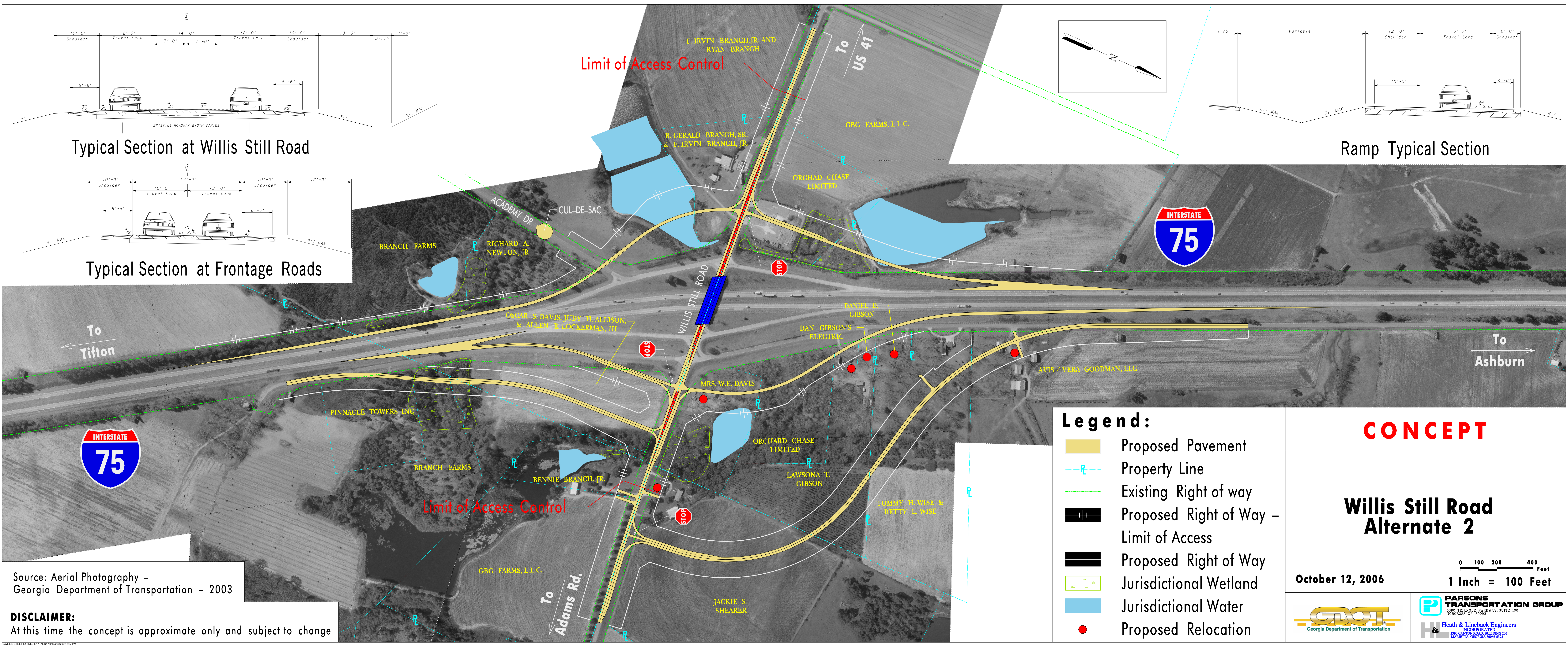

- Legend:**
- Proposed Pavement
 - Property Line
 - Existing Right of way
 - Proposed Right of Way – Limit of Access
 - Proposed Right of Way Jurisdictional Wetland
 - Jurisdictional Wetland
 - Jurisdictional Water
 - Proposed Relocation

CONCEPT

Willis Still Road Alternate 2

October 12, 2006

0 100 200 400 Feet
1 Inch = 100 Feet

Source: Aerial Photography – Georgia Department of Transportation – 2003

DISCLAIMER:
At this time the concept is approximate only and subject to change

PARSONS TRANSPORTATION GROUP
INCORPORATED
5300 TRIANGLE PARKWAY, SUITE 100
NORCROSS, GA 30092

Heath & Lineback Engineers
INCORPORATED
2390 CANTON ROAD, BUILDING 200
MARIETTA, GEORGIA 30066-5393